

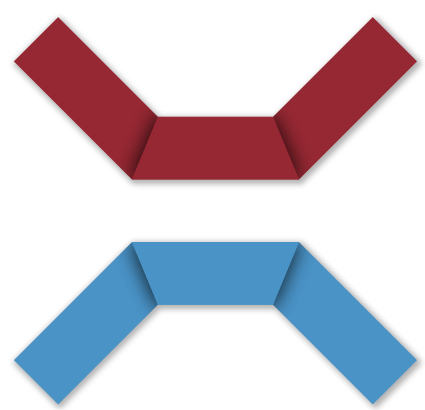

Aluminium



HOLMAK

Healthier environments,
happier people.

**Counterflow Heat
Exchangers from Holmak**

Using the counterflow principle to minimize thermal energy losses.

The special design of the Aluminium plates ensures there is a sufficient airflow even at lowest flow rates.

ALUMINIUM HEAT EXCHANGERS FROM HOLMAK

- High manufactured quality based on a longstanding production track record
- Short lead times thanks to highly flexible production and logistics
- Drawing on cutting-edge technology
- Specific design increases high efficiency at all air volumes
- High tightness and stability thanks to double folding technology

When separate supply and return airflows pass each other in opposite directions (counterflow principle), the warm air in one duct can heat up the cold air in the other duct by means of thin, parallel, highly conductive aluminium plates. The principle of course also works in reverse, for cooling down warm air. This energy transfer can be bridged with an optional bypass.



Extensive product portfolio for a wide range of applications.

Thanks to the broad functionality of our products and the flexible organisation of our company, we are in a position to meet a wide range of requirements.

Holmak counterflow heat exchangers are used as key components in a broad range of ventilation systems. Our goal is always to achieve an efficient exchange of cooling or heating energy

- for central ventilation,
- for decentral ventilation,
- for heat recovery in winter,
- for cold recovery in summer.

Our products are distributed worldwide and used in wide-ranging reference projects.

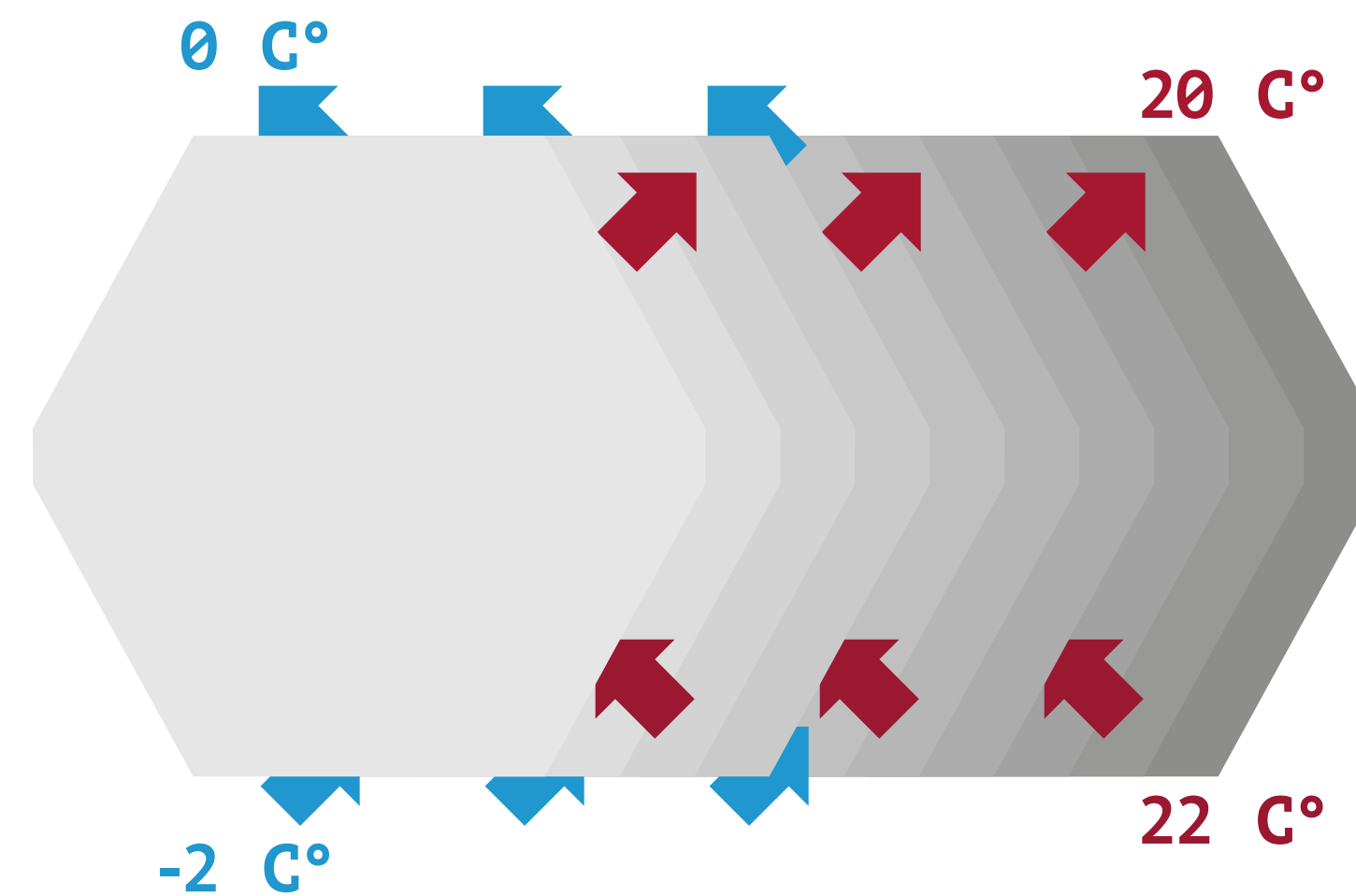

Aluminium Heat Exchangers

Optimal performance for big air volumes.

Heat exchangers are the heart of the air handling system. Made from high-grade aluminium with optimal drainage and sealless design, performance is optimized up to 95% with low pressure drop. Produced and manufactured to the highest Eurovent standards and according to the EN308 norms, you can be sure of years of trouble-free performance.

- Seawater-resistant aluminium for supreme quality
- Optimal drainage for high standard of hygiene
- Silicone-free design
- Length adjustable flexibly over range from 150 to 800 mm
- For a wide range of air volumes per unit
- For big air volumes, choose our combination systems.

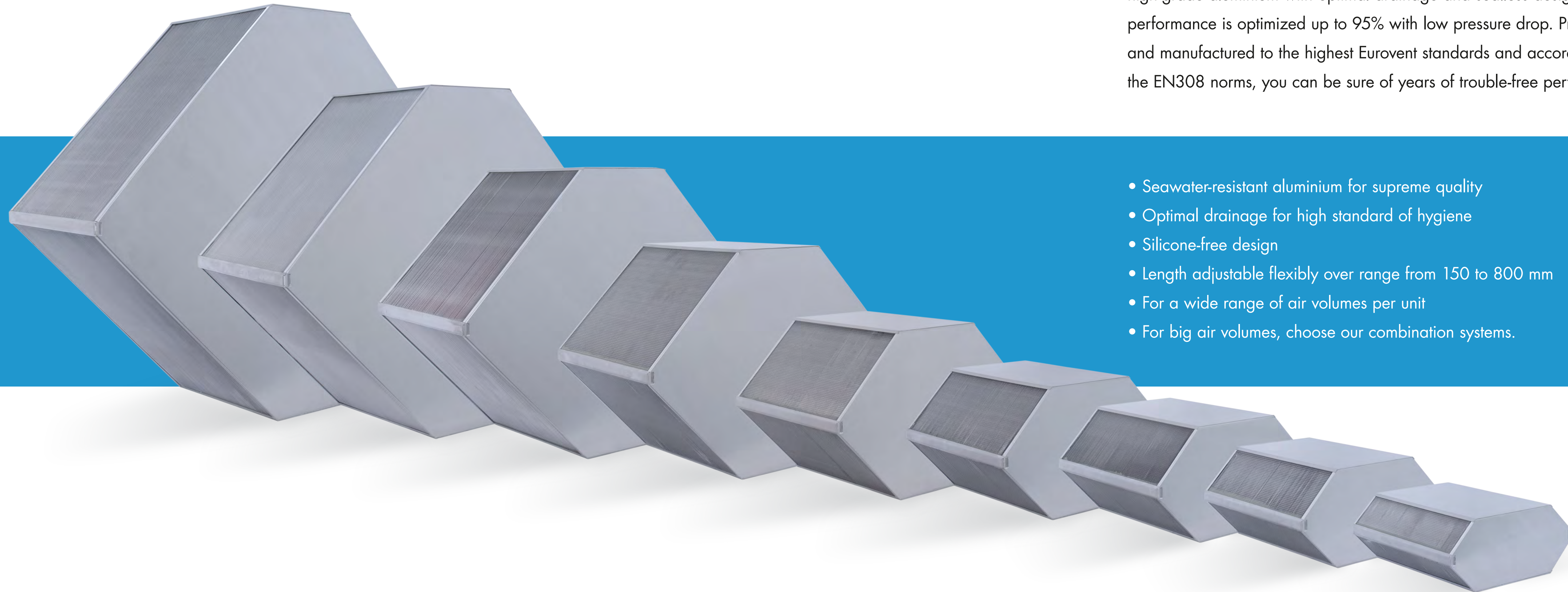

GS line

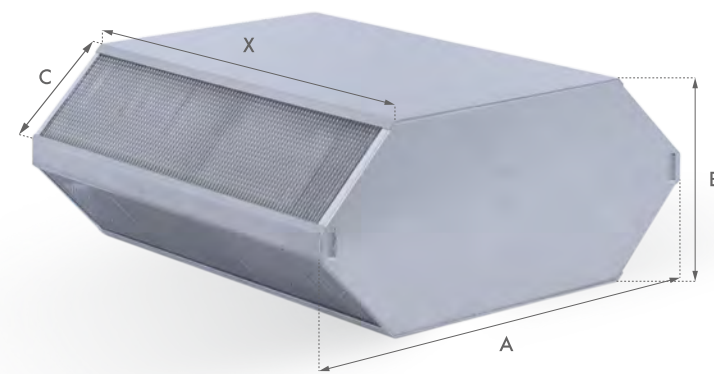

GS18

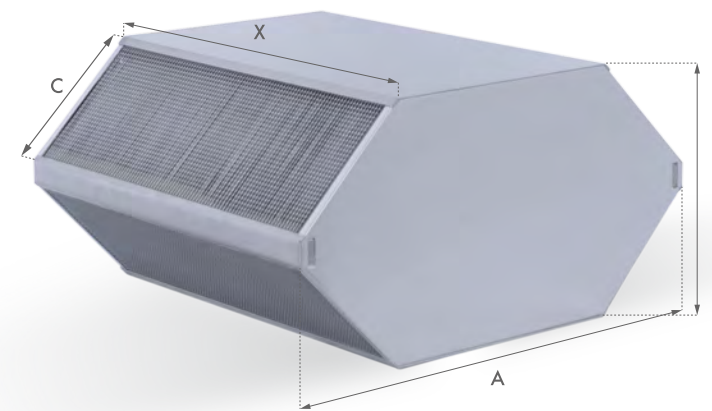

GS25

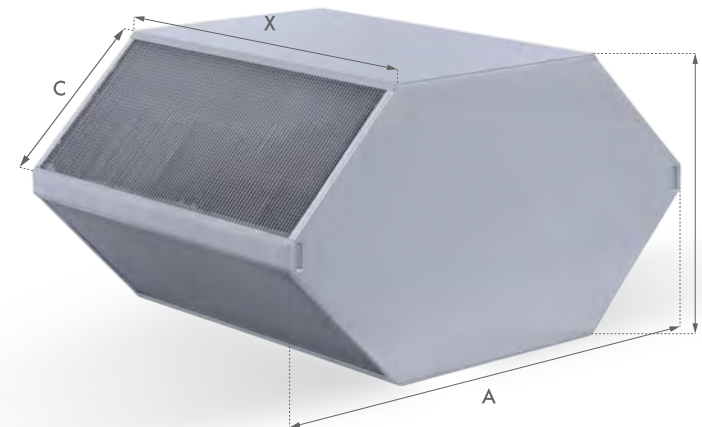

GS30

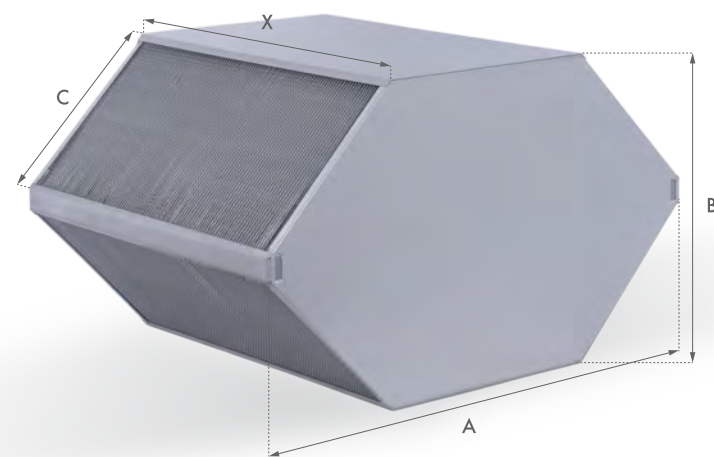

GS35

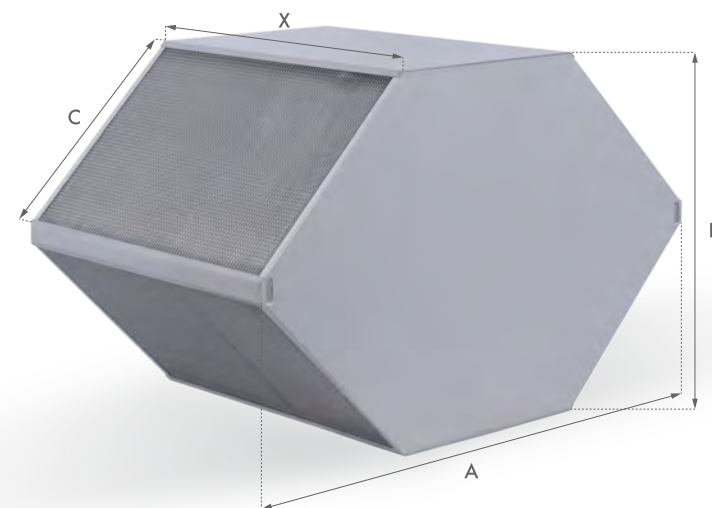

GS45

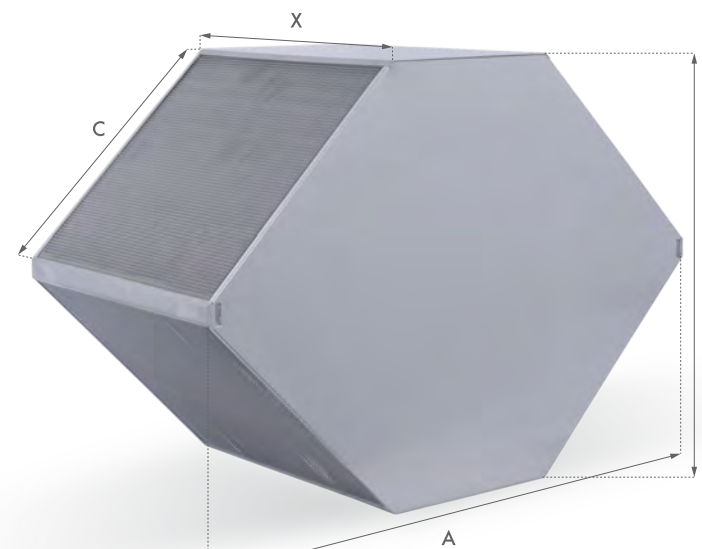

GS62

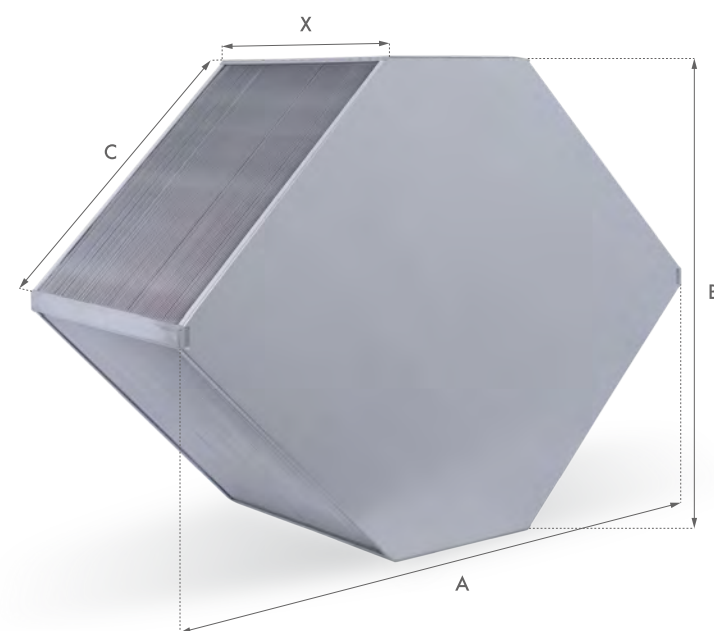

GS80

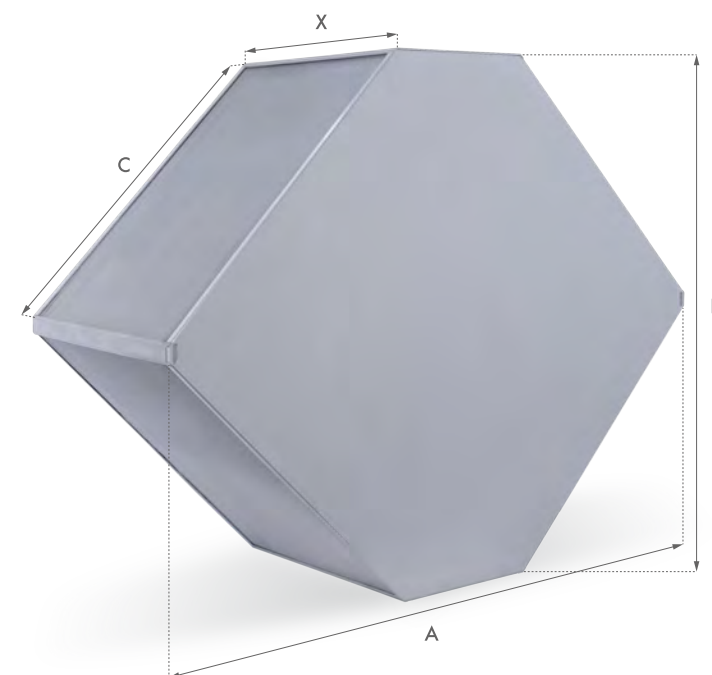

GS95

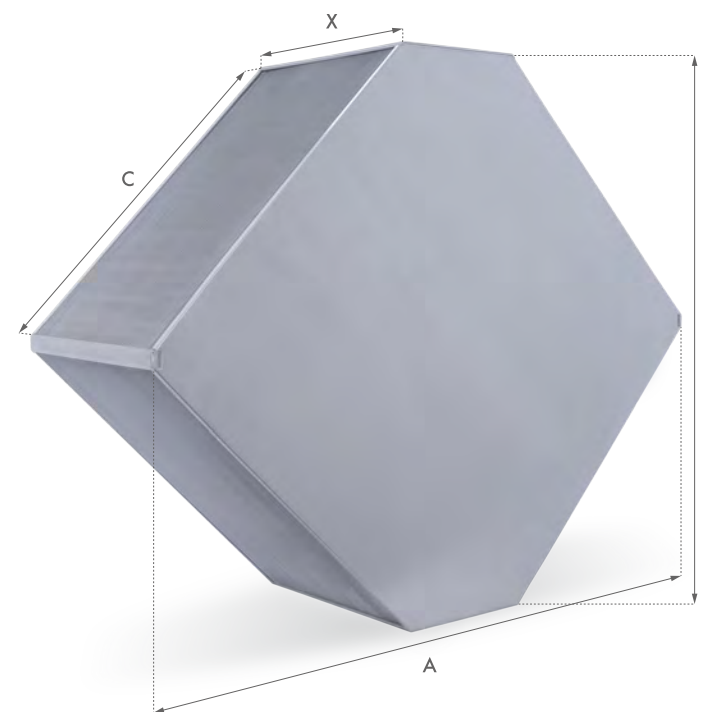

GS110

Type	A (mm)	B (mm)	C (mm)	X (mm)
GS18	397	172	107	100-430
GS25	454	230	148	100-750
GS30	496	271	177	100-710
GS35	537	312	206	100-800
GS45	619	394	263	100-720
GS62	758	533	361	100-700
GS80	899	674	461	100-600
GS95	1040	815	561	100-600
GS110	1182	957	662	100-600

GS line



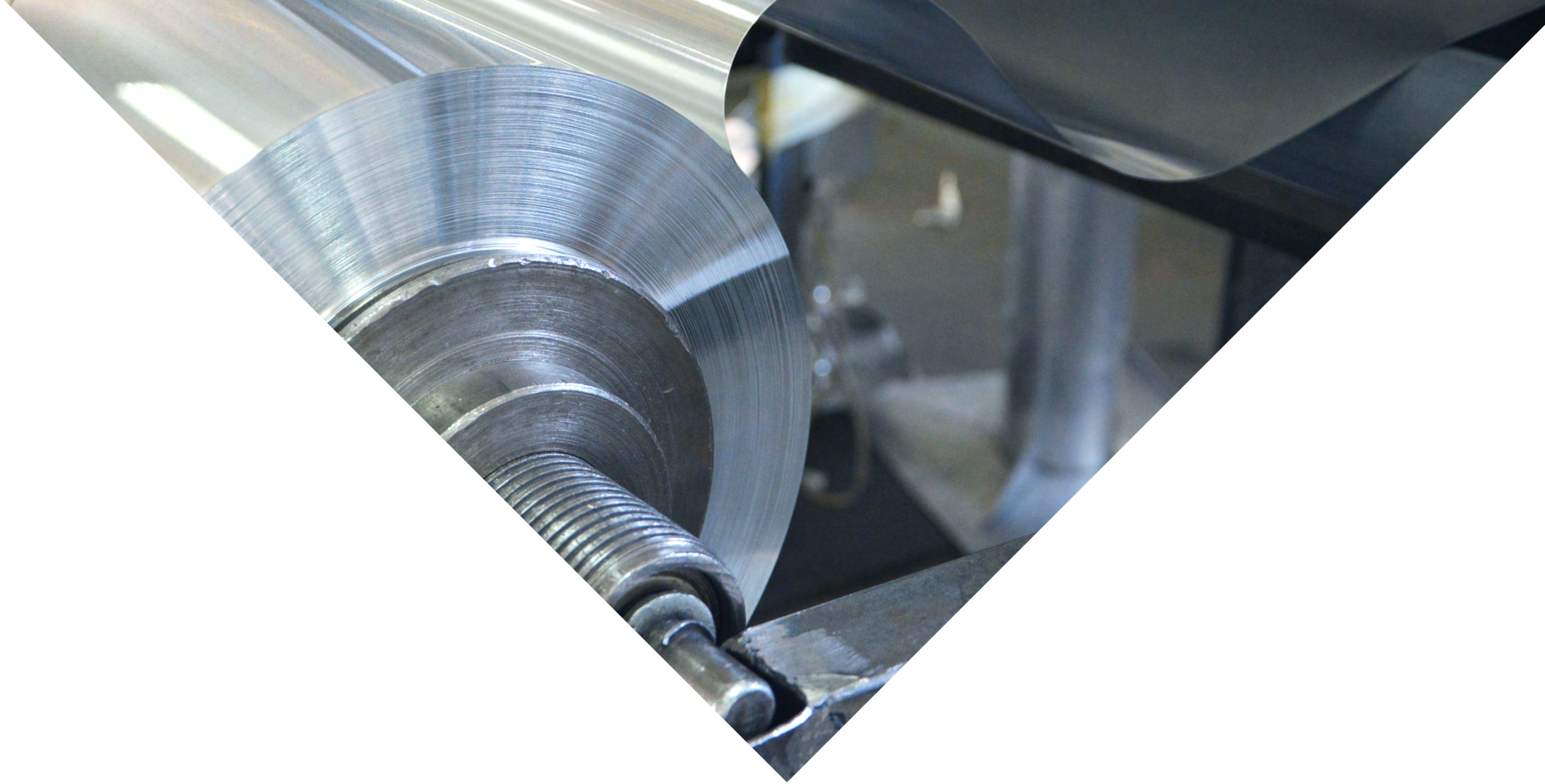

Up to 95% thermal efficiency with lowest pressure loss.

GS line

Standard Air Volume [m³/h]

Unit width [mm]

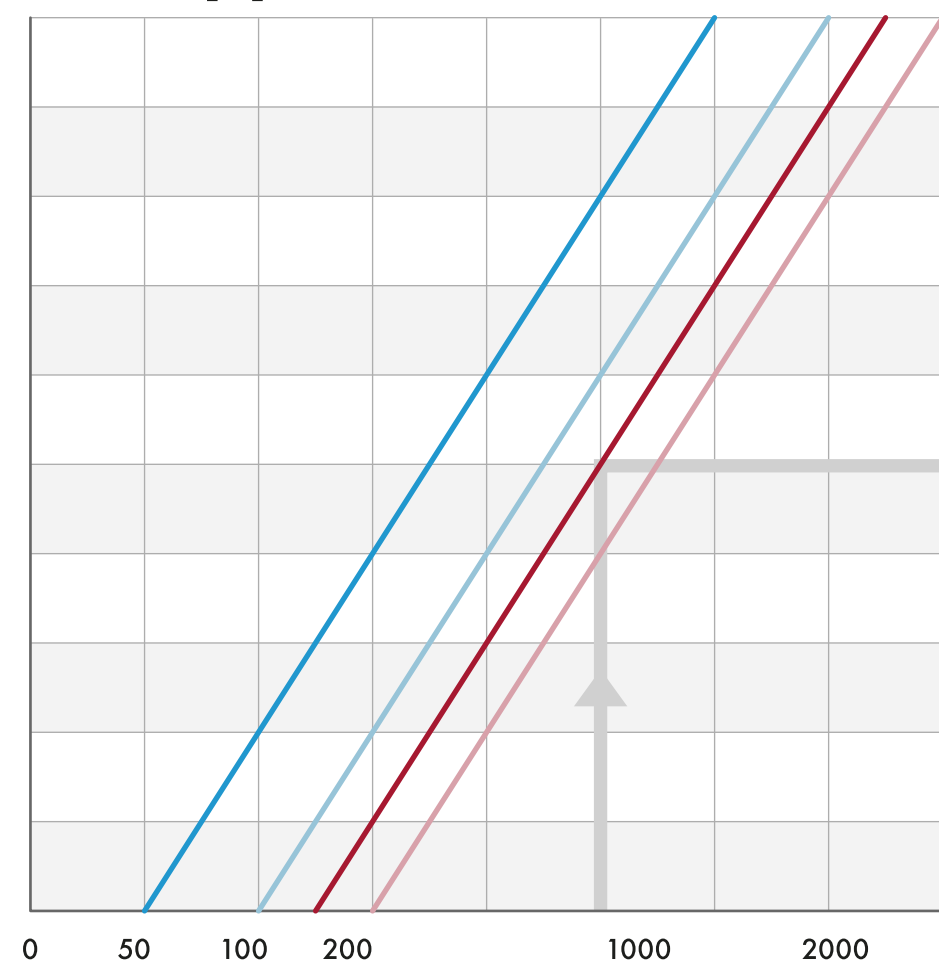

Pressure drop [Pa]

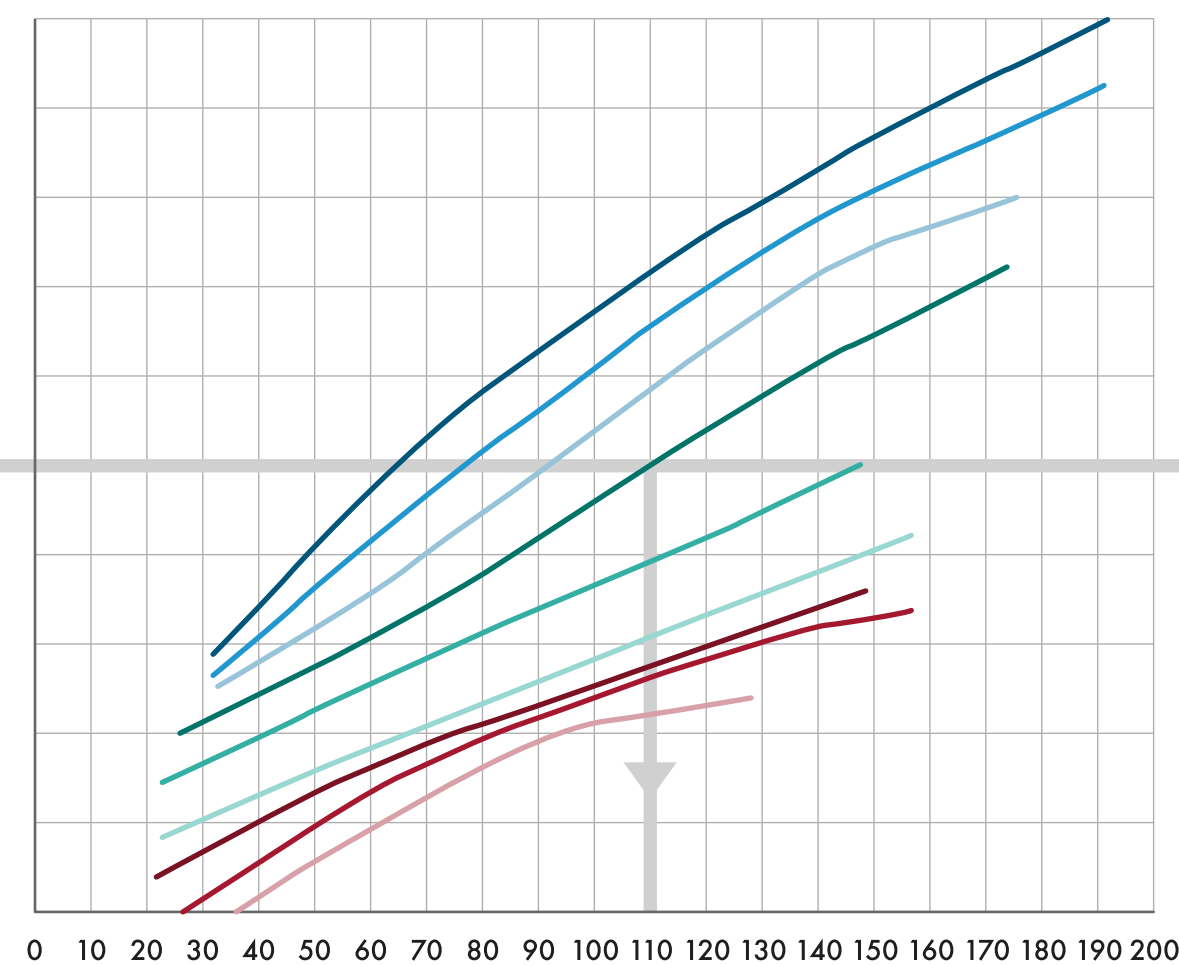

Efficiency [%]

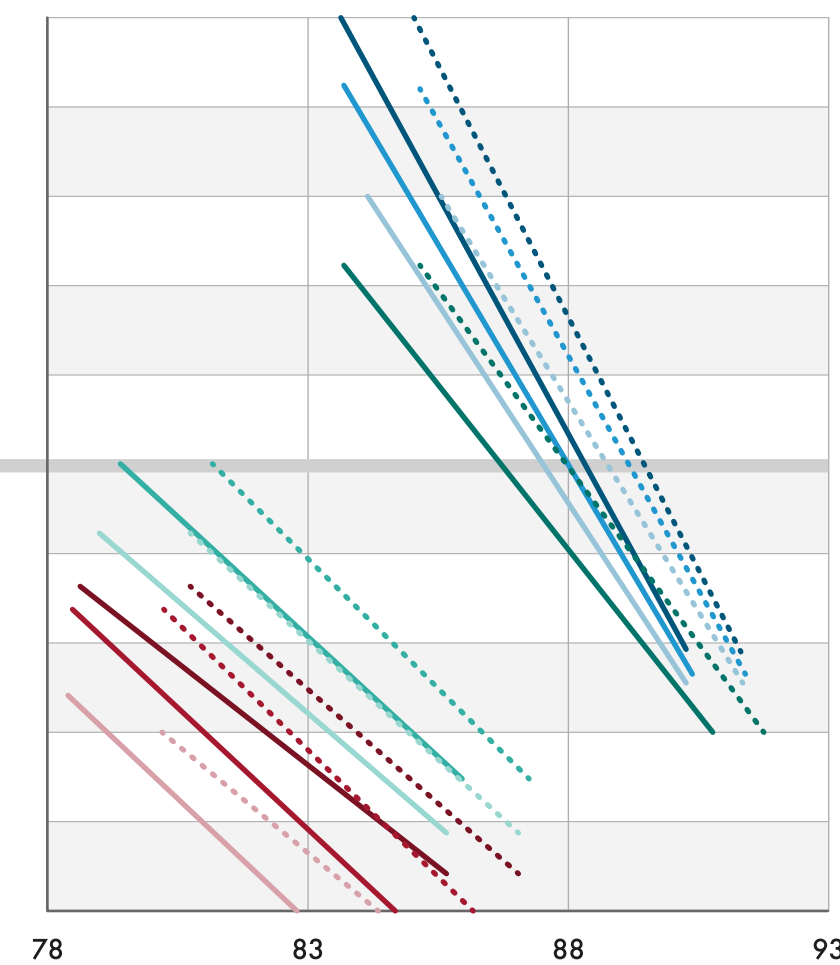

— 200 — 300 — 400 — 500

— 110 — 95 — 80 — 62 — 45
— 35 — 30 — 25 — 18

DRY — 110 — 95 — 80 — 62 — 45
— 35 — 30 — 25 — 18
WET ··· 110 ··· 95 ··· 80 ··· 62 ··· 45
··· 35 ··· 30 ··· 25 ··· 18

Thanks to the specific design, a Holmak heat exchanger achieves high energy efficiency combined with lowest pressure loss across the entire range of air volumes.

- For a wide range of air volumes per unit
- Up to 95 % thermal efficiency with lowest pressure loss
- Lowest SFP (specific fan power) is obtained

Our aluminium GS Kombi range

Fantastic performances for bigger air volumes

For bigger air volumes we offer our aluminium GS Kombi range. With the GS Kombi range we are able to achieve big performances by combining two similar parallel build heat exchangers. The aluminium is seawater resistant and by using our special folding technique for the aluminium blisters, the airtightness is guaranteed.

- For bigger air volumes we offer our GS Kombi range
- Air flows up to 20.000m³/h
- Efficiencies up to 93%
- Low pressure drop due to intelligent design

GS Kombi



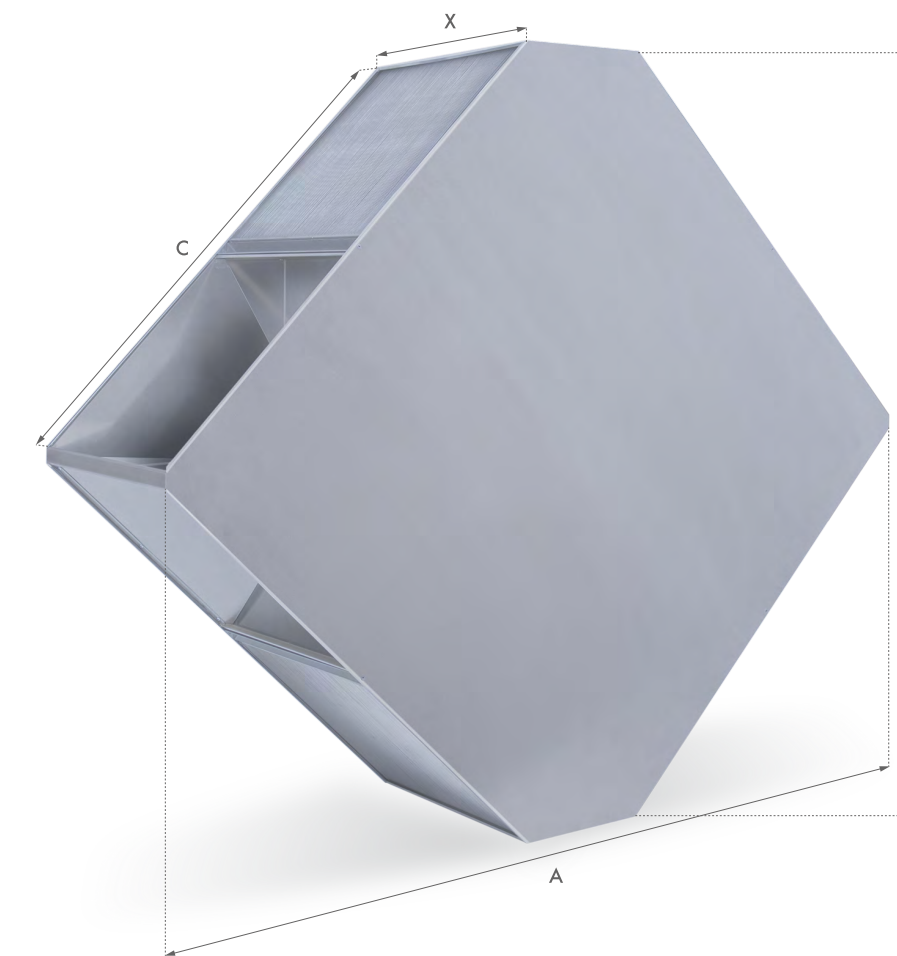
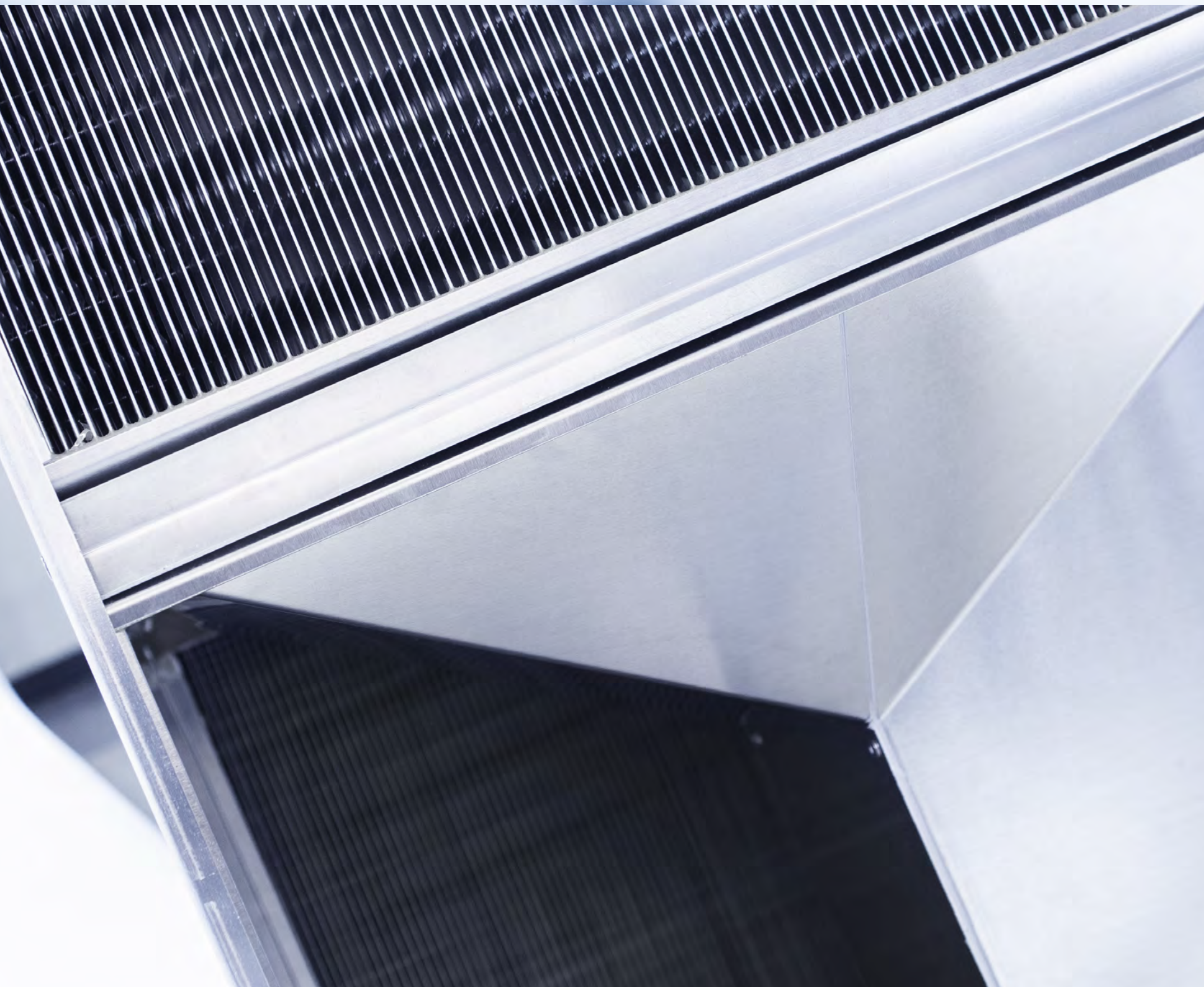

GS Kombi



GS Kombi	A (mm)	B (mm)	C (mm)	X (mm)
62	1314	1089	749	500
80	1600	1376	952	450
95	1887	1662	1155	400
110	2170	1945	1354	350

Cutting-edge technology for customers who expect more.

We are constantly testing new materials and designs in an effort to provide our customers with an innovative range of products, featuring state-of-the-art technology.

We are researchers

We work with the most modern calculation software in order to continuously optimize the air flow and thermodynamics of our designs.

We are developers.

In testing new materials and concepts, we are able to constantly improve both our products and our own level of expertise. We work close with technical universities.

Please visit our website to download our calculation software: www.holmak.eu





This is Holmak

Specialist for air heat exchangers.

In focusing on counterflow heat exchangers, we declare our commitment to keep continuously optimising this technology.

Holmak was established in 2007 under Dutch management as a production company located in North Macedonia. Research & Development, Design and Sales, plus a part of the production process are based in Staphorst, the Netherlands.

Netherlands

HOLMAK HEATX B.V.

WETHOUDER WASSEBALIESTRAAT 8

7951 SN STAPHORST

+31 522 469 900

North Macedonia

HOLMAK D.O.O.E.L.

KIRIL VANGELOV MAKEDONSKI BR. 50

7000 BITOLA

info@holmak.eu

www.holmak.eu

